

SSCV SERIES SET PRESSURE VS FLOW RATE

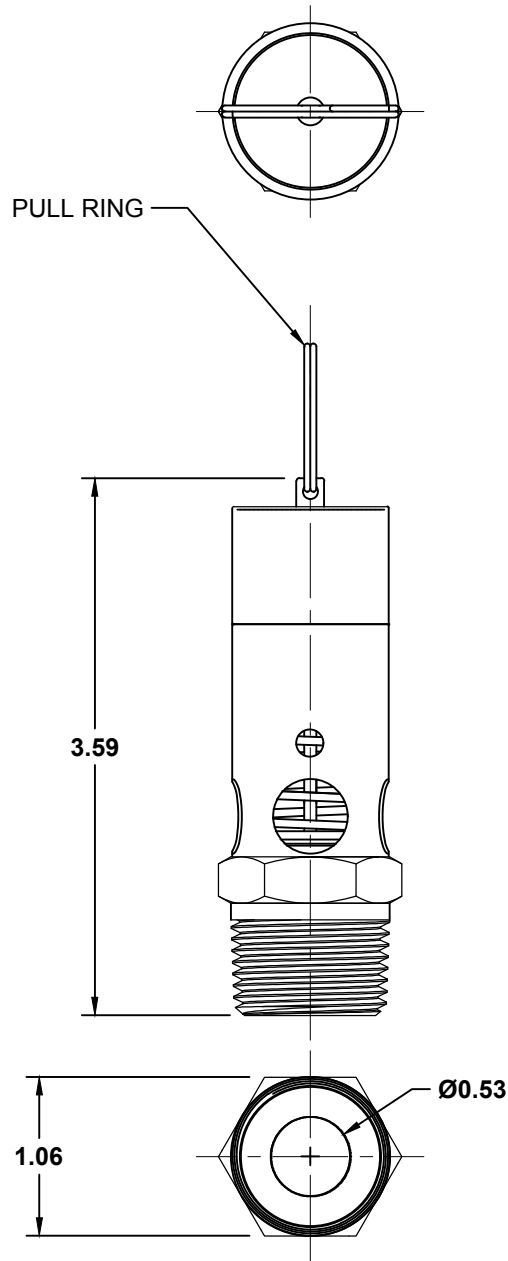
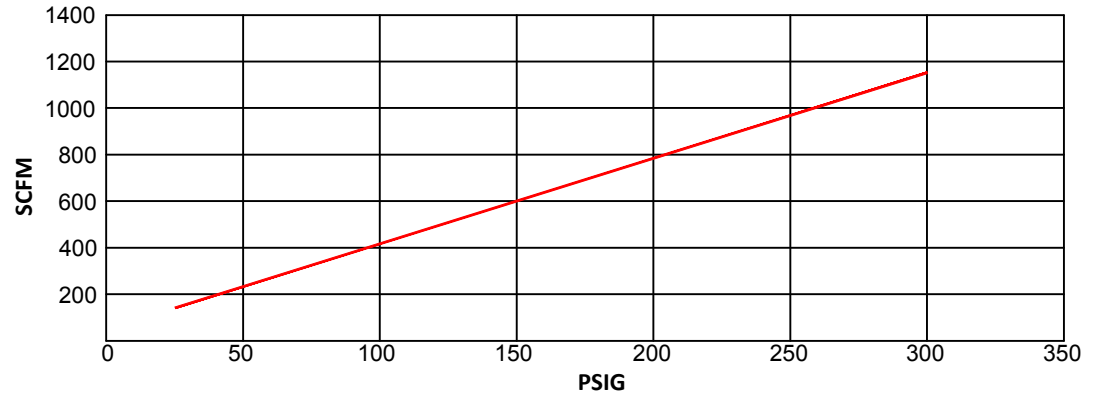

SPECIFICATIONS

BODY	ASTM B-16 STAINLESS
SPRING	304 STAINLESS STEEL
SEAL	VITON
RATINGS:	ASME, UB, UV & CRNUNFIRED PRESSURE VESSEL
OPTIONS:	VITON (SEAL)
TEMP RANGE	0°F TO 350°F
SIZES	1/2 AND 3/4 NPT
PRESSURES	25 TO 300 PSIG
ACCURACY	±3% OF SET PRESSURE ±2% UNDER 70 PSI

NOTE:

TO ORDER 1/2" NPT, USE SSCV4-**

FOR 3/4" NPT, USE SSCV6-**

USE SUFFIX TO SPECIFY SET PRESSURE.

EXAMPLE: "SSCV6-50" = 3/4" NPT VALVE SET TO 50PSI



DRAWING NAME:
1/2 NPT AND 3/4 NPT SSCV-SERIES STAINLESS STEEL
RELIEF VALVES

MATERIAL:	A	DRAWING NUMBER: SSCV-SERIES	REV. 1
SCALE: N.T.S.	NAME: MCH	DATE:	9-22-17