

VALVE SIZE
INCHES
0.50
0.75
1.00
1.50
2.00
2.50
3.00
4.00
5.00
6.00
8.00
10.00
12.00
14.00
16.00
18.00
20.00
24.00
28.00
30.00
32.00
36.00
40.00
42.00
48.00

CLASS 125/150			
BOLT CIRCLE	BOLT SIZE (LUG)	HOLE DIA (WAFER)	NO OF HOLES
2.38	1/2	0.62	4
2.75	1/2	5/8	4
3.13	1/2	0.62	4
3.88	1/2	0.62	4
4.75	5/8	0.75	4
5.50	5/8	0.75	4
6.00	5/8	0.75	4
7.50	5/8	0.75	8
8.50	3/4	0.88	8
9.50	3/4	0.88	8
11.75	3/4	0.88	8
14.25	7/8	1.00	12
17.00	7/8	1.00	12
18.75	1	1.12	12
21.25	1	1.12	16
22.75	1-1/8	1.25	20
25.00	1-1/8	1.25	20
29.50	1-1/4	1.38	20
34.00	1-1/4	--	28
36.00	1-1/4	--	28
38.50	1-1/2	--	28
42.75	1-1/2	--	32
47.25	1-1/2	--	36
49.50	1-1/2	--	36
56.00	1-1/2	--	44

CLASS 300			
BOLT CIRCLE	BOLT SIZE	HOLE DIA (WAFER)	NO OF HOLES
2.62	1/2	0.62	4
3.25	5/8	0.75	4
3.50	5/8	0.75	4
4.50	3/4	0.88	4
5.00	5/8	0.75	8
5.88	3/4	0.88	8
6.63	3/4	0.88	8
7.87	3/4	0.88	8
9.25	3/4	0.88	8
10.63	3/4	0.88	12
13.00	7/8	1.00	12
15.25	1.00	1.12	16
17.75	1-1/8	1.25	16
20.25	1-1/8	1.25	20
22.50	1-1/4	1.38	20
24.75	1-1/4	1.38	24
27.00	1-1/4	1.38	24
32.00	1 1/2	1.62	24

CLASS 600		
BOLT CIRCLE	BOLT SIZE	NO OF HOLES
4.50	3/4	4
5.00	5/8	8
5.88	3/4	8
6.63	3/4	8
8.50	7/8	8
10.50	1	8
11.50	1	12
13.75	1-1/8	12
17.00	1-1/4	16
19.25	1-1/4	20
20.75	1-3/8	20
23.75	1-1/2	20
25.75	1-5/8	20
28.50	1-5/8	24
33.00	1 7/8	24

NOTE:
THIS IS A GENERAL TABLE OF COMMON SIZES, FOR USE IN APPROXIMATING VALVE SIZE AND ANSI RATING. READ ALL TAGS ON CURRENT VALVES (IF APPLICABLE) TO DETERMINE CORRECT SIZE AND RATING. ULTIMATE DECISION ON SPECIFYING PROPER VALVE IS THE RESPONSIBILITY OF THE END USER.

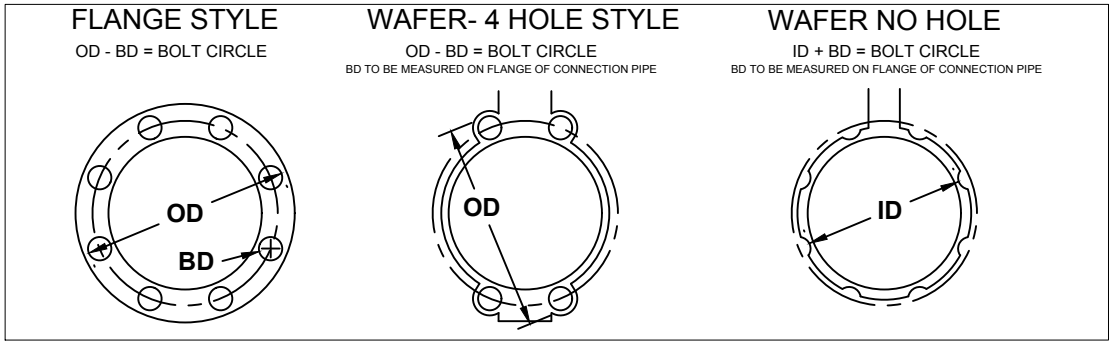

NOTE: BD = BOLT DIAMETER. ID = INNER DIAMETER OD = OUTER DIAMETER

THIS DOCUMENT IS PROPERTY OF UNIVERSAL COMPONENTS, INC. ANY REPRODUCTION, DISCLOSURE, OR USE OF THIS DOCUMENT IS EXPRESSLY PROHIBITED UNLESS OTHERWISE AGREED UPON IN WRITING. *ALL SPECIFICATIONS SUBJECT TO CHANGE WITHOUT NOTICE.*



DRAWING NAME:
ANSI CLASS FLANGE DIMENSIONS

MATERIAL:	A	DRAWING NUMBER: FLANGE-DIMENSIONS	REV. 2
SCALE: N.T.S.	NAME: MCH	DATE: 9-21-21	