

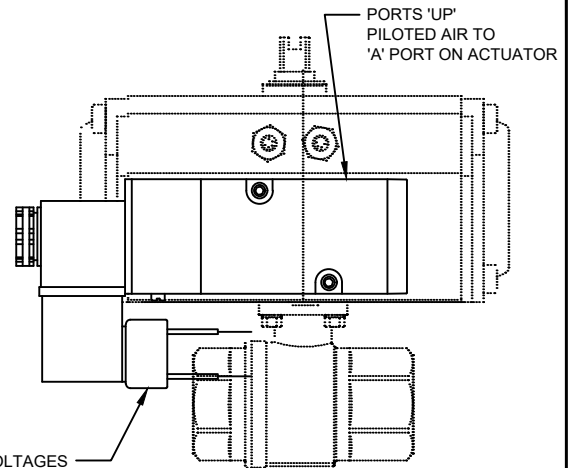

UNIVERSAL COMPONENTS, INC

N4S SERIES SOLENOID VALVE: INSTALLATION INFORMATION

TYPICAL INSTALLATION CONFIGURATIONS

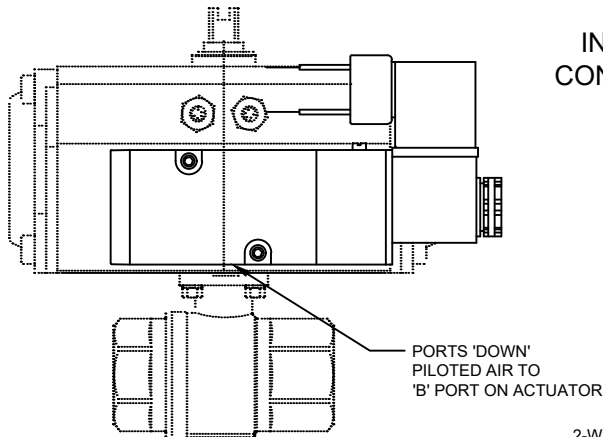

2-WIRE INPUT (TYPICAL) ALL VOLTAGES
CONDUIT CONNECTION SHOWN,
ALSO AVAILABLE IN DIN STYLE

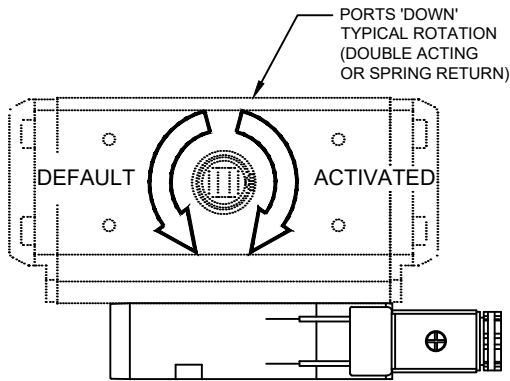

SOLENOID VALVE SHOWN ON
PNEUMATIC ACTUATED 2-WAY
BALL VALVE ASSEMBLY, BUT IS
SUITABLE FOR MANY OTHER
APPLICATIONS. CONSULT
CATALOG OR FACTORY FOR
FURTHER INFORMATION AND
USAGE OPTIONS, INCLUDING
EXPLOSION PROOF, DOUBLE
COIL AND REVERSE PORT FLOW.

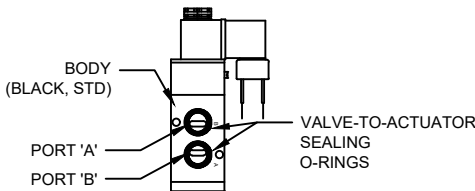
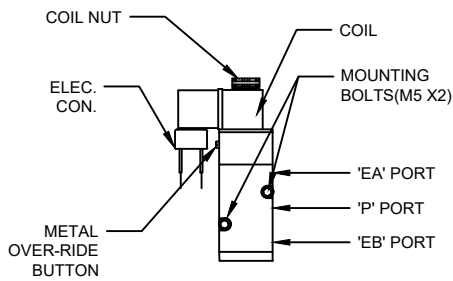
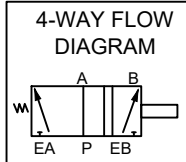
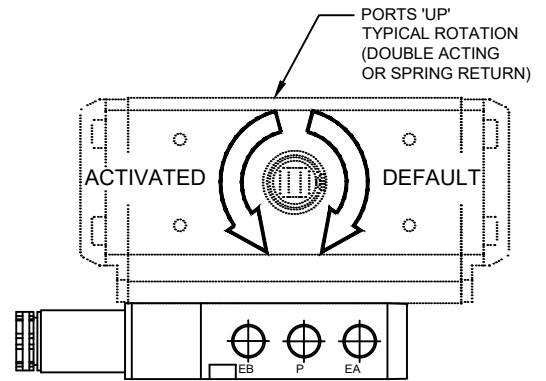

MANUAL OVER RIDE

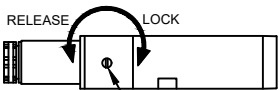

USAGE

- TO ACTIVATE MOMENTARILY, PUSH DOWN. RELEASE TO END OVER RIDE.
- TO LOCK INTO OVER-RIDE, USE SMALL FLAT HEAD SCREWDRIVER, PRESS DOWN, ROTATE 1/4 TURN CLOCKWISE.
- TO DE-ACTIVATE, PRESS DOWN, ROTATE 1/4 TURN COUNTER-CLOCKWISE, AND RELEASE

INSTALLATION NOTES:

ALL ELECTRICAL POWER MUST BE 'OFF' AND AIR PRESSURE MUST AT '0' WITH LINE SUPPLY OFF PRIOR TO AND DURING INSTALLATION. EQUIPMENT DAMAGE, INJURY OR DEATH MAY OCCUR OTHERWISE

- USE SUPPLIED M5 SCREWS (25, 30 OR 35 LENGTH DEPENDING UPON ACTUATOR)
- MAKE SURE O-RINGS ARE IN PLACE ON OUTPUT SIDE (A, B PORT)
- ONLY APPLY VOLTAGE DENOTED ON COIL. ANY OTHER APPLIED VOLTAGE ASIDE FROM WHAT IS PRINTED ON COIL MAY RESULT IN DAMAGE SYSTEM DAMAGE, NON-OPERATION, OR/AND INJURY OR FIRE.
- VALVE REQUIRES A MINIMUM OF 80 PSI DRY OR OILED, CLEAN AIR, TO PORT 'P'.
- CONNECT ELECTRICAL SIGNAL WIRES, AVAILABLE VOLTAGES ARE :

12 VAC	12VDC
24VAC	24VDC
110 VAC	220 VAC
- SUPPLIED AIR TO BE TO PORT 'P' ON BODY ONLY
- NON-ENERGIZED FLOW:
 PORT 'A' WILL BE ACTIVE IN NON ENERGIZED POSITION,
 PORT 'EB' WILL BE OPEN TO EXHAUST FROM PORT 'B'.
 PORT 'B' ACTIVE WHEN VALVE IS ENERGIZED, PORT 'EA' WILL BE OPEN TO EXHAUST FROM PORT 'A'

PLEASE CONTACT US FOR OPTIONS, APPLICATION,
ORDERING AND ANY OTHER INQUIRIES

EXHAUST OUTPUT OPTIONS

ADJUSTABLE SPEED CONTROLS

ALLOW FOR PRECISE CONTROL OF OPENING AND CLOSING SPEEDS. ALSO FILTERS OUT EXTERNAL DEBRIS AND CONTAMINATES. CAN BE USED ON ONE OR BOTH EXHAUST PORTS

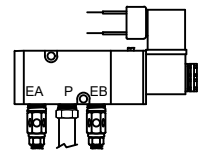

MUFFLERS AND BREATHER VENTS

FILTERS OUT EXTERNAL DEBRIS AND CONTAMINATES. CAN BE USED ON ONE OR BOTH EXHAUST PORTS. REDUCES SOUND LEVEL

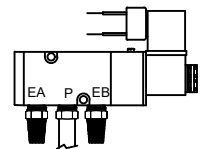

PLUMB TO EXTERNAL TANK OR CONTROL

PLUMB EXHAUSTS OUT TO EXTERNAL TANK, EXTERIOR REMOTE VENT, OR ANOTHER PNEUMATIC DEVICE FOR INPUT SIGNAL

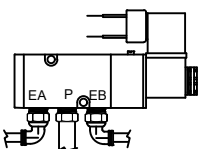

UNIVERSAL COMPONENTS, INC
1313 HALL SPENCER ROAD
ROCKHILL, SC, 29730
803-324-5176
WWW.UCIMFG.COM