

SHM-T SERIES BALL VALVE



FEATURES:

- CF8M Stainless Steel 3-Way L-Port Diverter Valve
- 29" Hg-800psi WOG, Cold Non-Shock
- 150psi Saturated Steam
- CF8M Body, 316 Stainless Ball and Stem
- Blowout Proof Stem w/Adjustable Stem Packing
- RPTFE Seats and PTFE Seals
- Meets NACE MR0175 (2000) & MR0103 (2012)
- Temperature -35°F to 400°F

DIMENSIONS

Part#	NPT	A	B	C	D	Cv	Wt Lbs.
SHM-2T	1/4"	2.32	1.12	1.80	3.88	2	0.70
SHM-3T	3/8"	2.32	1.12	1.80	3.88	4	0.68
SHM-4T	1/2"	2.32	1.12	1.80	3.88	5	0.75
SHM-6T	3/4"	2.97	1.47	2.06	4.78	12	1.45
SHM-8T	1"	3.20	1.60	2.15	4.78	14	1.86
SHM-12T	1-1/2"	4.38	1.99	3.03	5.43	34	4.67
SHM-16T	2"	5.45	2.75	3.22	5.43	47	7.02

SUFFIX OPTIONS:

- HT = High Temp Option (250Lb Steam)
- BSPP = BSPP threads, parallel, 1/4" to 2"
- BSPT = BSPT threads, tapered, 1/4" to 2"
- OX = Oxygen Cleaned

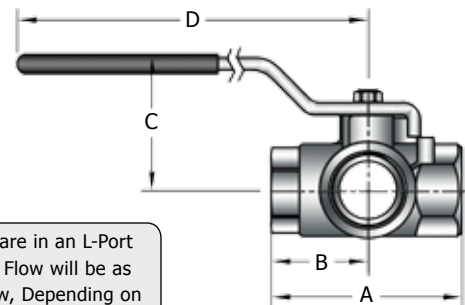

SHM-T Valves are in an L-Port Configuration. Flow will be as Depicted Below, Depending on Lever Position

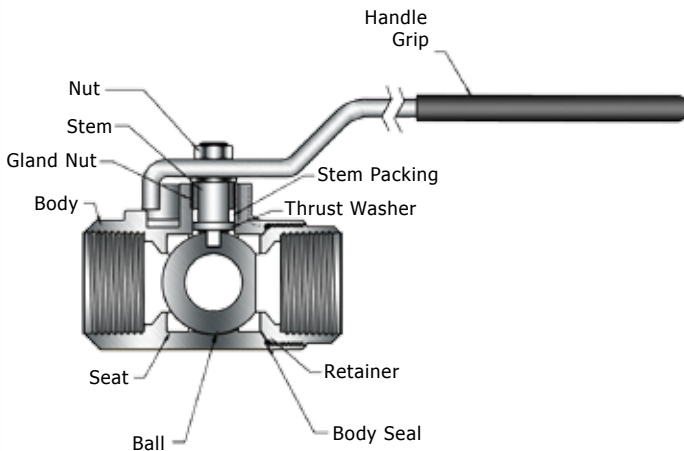

BILL OF MATERIALS

PART	Material
Lever	304 Stainless Steel
Grip	Vinyl
Stem Packing	MPTFE
Stem Bearing	RPTFE
Ball	A276-316 Stainless Steel
Seat	RPTFE
Retainer	A276-316 SS 1/4"-1"/A351-CF8M 1-1/2"-2"
Gland Nut	A276-316 Stainless Steel
Stem	A276-316 Stainless Steel
Lever Nut	18-8 Stainless Steel
Body Seal	PTFE
Body	A351-CF8M Stainless Steel