



SHM SERIES BALL VALVE



MSS SP-110 Compliant

FEATURES:

- CF8M Stainless Steel Ball Valve
- 29" Hg-2000psi WOG (1/4" to 1")
- 29" Hg-1500psi WOG (1-1/4" to 2")
- 29" Hg-1000psi WOG (2-1/2" to 3")
- 150psi Saturated Steam
- RPTFE Seats and PTFE Seals
- Blowout Proof Stem with Adjustable Packing
- Temperature -35°F to 400°F

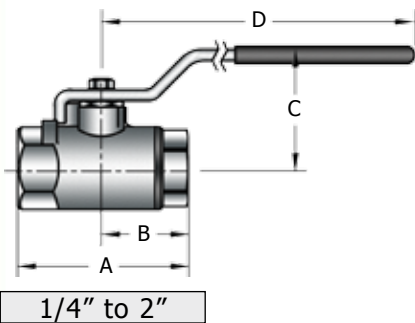

1/4" to 2"

DIMENSIONS

Part#	NPT	A	B	C	D	Cv	Wt. Lbs.
SHM-2	1/4"	2.05	1.02	1.71	3.85	8	0.60
SHM-3	3/8"	2.05	1.02	1.71	3.85	7	0.56
SHM-4	1/2"	2.23	1.12	1.79	3.85	15	0.63
SHM-6	3/4"	2.96	1.47	2.03	4.75	30	1.39
SHM-8	1"	3.34	1.67	2.16	4.75	43	1.72
SHM-10	1-1/4"	4.00	2.00	2.68	5.40	48	3.10
SHM-12	1-1/2"	4.34	2.17	3.25	7.75	84	4.20
SHM-16	2"	5.43	2.69	3.24	7.75	108	6.10
SHM-20	2-1/2"	6.75	3.38	4.03	7.75	190	15.6
SHM-24	3"	6.75	3.38	4.03	7.75	370	16.5

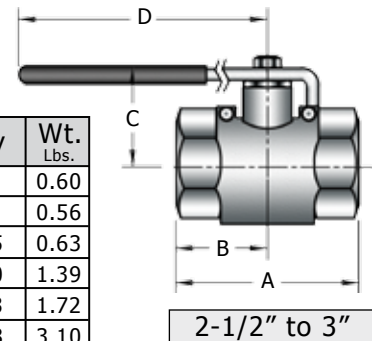

2-1/2" to 3"

BILL OF MATERIALS

PART	Material
Body	A351-CF8M Stainless Steel
Retainer	
Stem Bearing	RPTFE
Seat	
Body Seal	PTFE
Gland Nut	A276-316 Stainless Steel
Stem	
Ball	
Stem Packing	MPTFE
Handle	304 Stainless Steel
Nut	18-8 Stainless Steel
Grip	Vinyl

SUFFIX OPTIONS:

- HT = High Temp Option (250Lb Steam)
- BSPP = BSPP threads, parallel, 1/4" to 2"
- BSPT = BSPT threads, tapered, 1/4" to 2"
- OX = Oxygen Cleaned
- DMC = Spring Return Closed
- DMO = Spring Return Open

1/4" to 2" Valve Shown
2-1/2"-3" Valves Similar

