

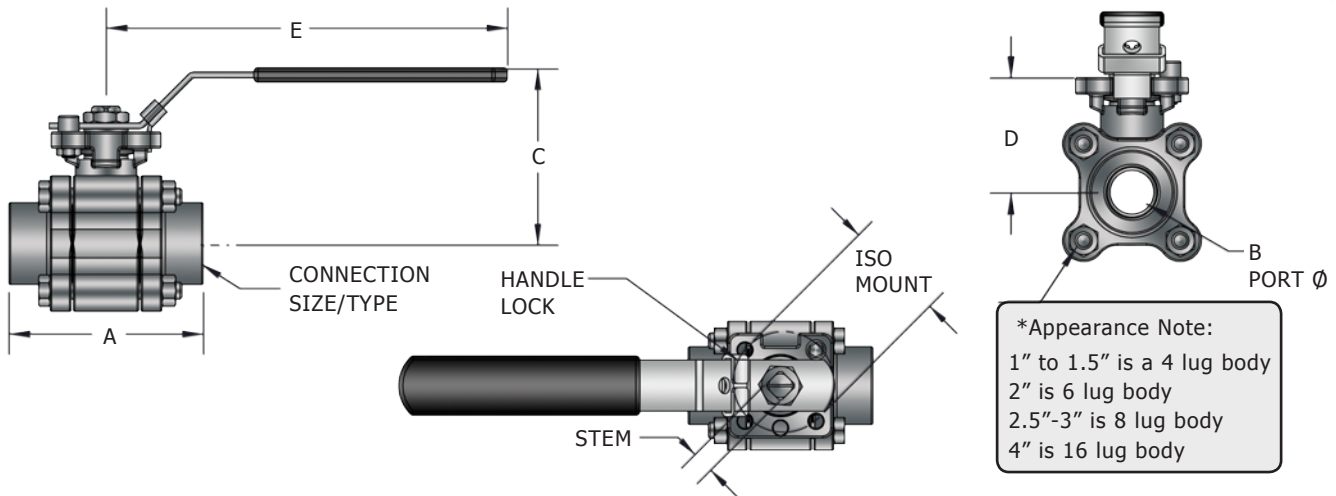

S3F22/C3F22 SERIES BALL VALVE

FEATURES:

- 3-Piece Stainless or Carbon Steel Ball Valve
- Fire Safe API 607 6th Ed, NACE MR0175
- 1/4" to 2" Carbon Steel 2,220 PSI, Stainless Steel 2,160 PSI, 2 1/2" to 4" 1,500 PSI
- Class 900 1/4" to 2", Class 600 2 1/2" to 4"
- Temperature Determined by Seat Material, *See Chart*
- Optional V-Ball Available
- Socket and Butt Weld Available



DIMENSIONS

Part # Stainless	Part # Carbon	NPT	A	B	C	D	E	Cv	Torque in/Lbs.	Wt. Lbs.	ISO Mount	STEM SQ (MM)
S3F22-2	C3F22-2	1/4"	2.61	0.43	2.18	1.81	5.12	8.5	71	1.5	F03/F04	9
S3F22-3	C3F22-3	3/8"	2.61	0.49	2.18	1.81	5.12	8.5	71	1.5		
S3F22-4	C3F22-4	1/2"	2.75	0.59	2.26	1.89	5.12	21	107	2.2		
S3F22-6	C3F22-6	3/4"	3.62	0.79	2.55	2.08	6.10	50	133	3.8	F04/F05	11
S3F22-8	C3F22-8	1"	4.13	0.98	2.79	2.32	6.10	90	160	5.6	F05/F07	14
S3F22-10	C3F22-10	1-1/4"	4.37	1.26	3.01	2.44	8.07	110	222	7.0		
S3F22-12	C3F22-12	1-1/2"	4.88	1.49	3.32	2.75	8.07	240	416	11		
S3F22-16	C3F22-16	2"	5.90	1.97	4.29	3.54	11.81	400	736	22	F07/F10	17
S3F22-20	C3F22-20	2-1/2"	6.49	2.50	4.84	4.13	13.78	700	1461	32	F10/F12	22
S3F22-24	C3F22-24	3"	7.68	3.07	5.66	4.68	15.75	980	2213	44		
S3F22-32	C3F22-32	4"	9.64	3.89	6.65	5.67	15.75	1700	3368	87		