



S3F SERIES BALL VALVE



FEATURES:

- Stainless Steel 3-Piece Full Port Ball Valve
- Latch Lock Handle Standard
- 29" Hg-1000psig WOG, Cold Non-Shock (1/4" to 2"), (800psi 2-1/2" to 4")
- Blow Out Proof Stem, with/Adjustable Stem Packing
- RTFE Seats with PTFE Stem Packing
- Temperature -20°F to 450°F

CONNECTION OPTIONS:

- NPT End = Standard (no suffix)
- Socket Weld = use Suffix "W"

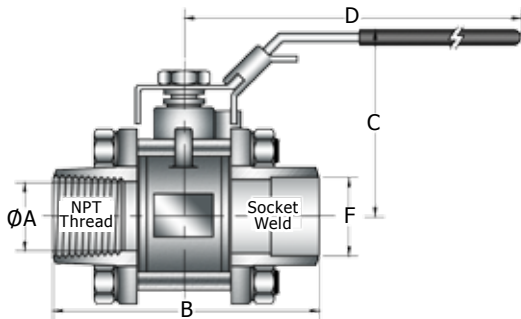

DIMENSIONS

Part #	NPT	ØA	B	C	D	F	Break Torque in/Lbs	Cv	Wt
S3F-2	1/4"	0.46	2.26	2.00	4.00	0.56	40	8	0.78
S3F-3	3/8"	0.51	2.26	2.00	4.00	0.70	40	10	0.74
S3F-4	1/2"	0.60	2.62	2.40	5.20	0.87	60	14	1.25
S3F-6	3/4"	0.80	3.05	2.56	5.20	1.09	80	24	1.67
S3F-8	1"	1.00	3.44	2.84	6.60	1.36	120	45	2.31
S3F-10	1-1/4"	1.28	4.11	3.12	6.60	1.71	240	82	3.88
S3F-12	1-1/2"	1.52	4.76	3.44	7.60	1.95	420	125	5.37
S3F-16	2"	2.00	5.26	3.80	7.60	2.44	560	200	8.16
S3F-20	2-1/2"	2.60	6.56	5.20	10.00	2.94	1100	290	15.83
S3F-24	3"	3.20	7.28	5.92	10.00	3.60	1600	470	23.42
S3F-32	4"	3.99	9.28	7.28	11.02	4.61	3200	800	46.29

BILL OF MATERIALS

PART	Material
Body	CF8M
End Cap	
Ball	316 Stainless Steel
Stem	
Stem Nut	304 Stainless Steel
Stem Washer	
Handle	RTFE
Seat	
Gland Nut	304 Stainless Steel
V-Ring Packing	
Thrust Washer	PTFE
Bolt Washer	
Joint Gasket	304 Stainless Steel
Bolt	
Locking Device	304 Stainless Steel
Handle Sleeve	
Bolt Nut	Vinyl
	304 Stainless Steel

