

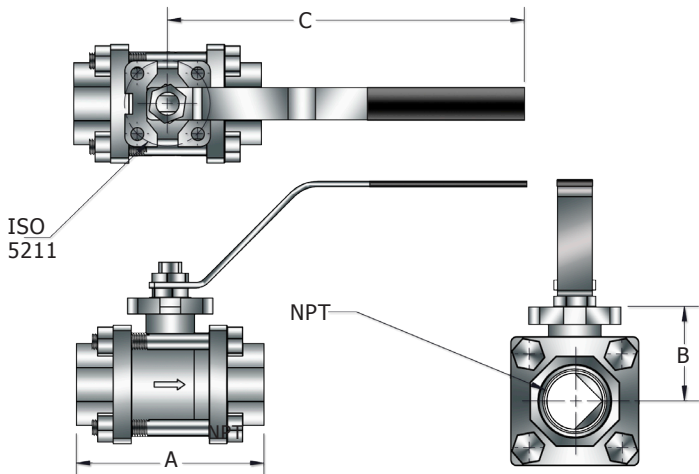

S3FV SERIES BALL VALVE

FEATURES:

- Stainless Steel 3-Piece, V-Cut Ball Valve
- 1,000 Psi (250 Psi Steam)
- NACE MR 017/ISO 15156 and NACE MR 0103 Compliant
- 90° V-Port Std. with 30°- 60° and 60° also available
- 25% Carbon PTFE Seats, RPTFE Stem Seal
- Viton Seat O-Ring & Stem O-Ring
- Temperature -4°F to 406°F



DIMENSIONS

Part #	NPT	A	B	C	ISO 5211
S3FV-4**	1/2"	2.55	1.26	5.17	F03
S3FV-6**	3/4"	2.99	1.43	5.17	F04
S3FV-8**	1"	3.62	1.60	6.87	F04
S3FV-10**	1-1/4"	4.19	1.77	6.87	F04
S3FV-12**	1-1/2"	4.56	2.17	9.86	F05
S3FV-16**	2"	5.35	2.42	9.86	F05
S3FV-24**	3"	7.08	3.38	12.65	F07
S3FV-32**	4"	8.54	4.04	15.01	F10

Note: ** = Degree of V-Port Opening (30-60,60,90 Degree)

BILL OF MATERIALS

PART	Material
Body	CF8M
Ball	
End Cap	304 Stainless Steel
Gland Bushing	
Handle	
Stem Nut	
Handle Washer	
Handle Nut	
Body Bolt	
Body Nut	
Washer	
Stem O-Ring	
Seat	50% SS + 50% PTFE
Packing Follower	PTFE + 25% GF
Grip	Vinyl

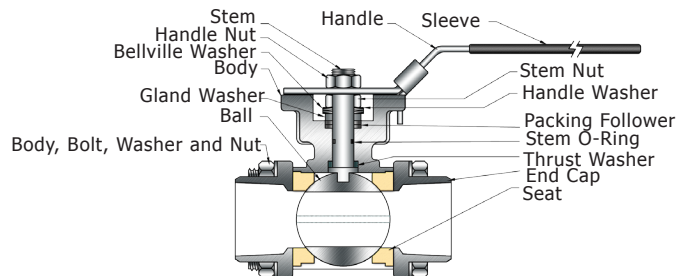

AVAILABLE V-PORT CONFIGURATIONS:

