

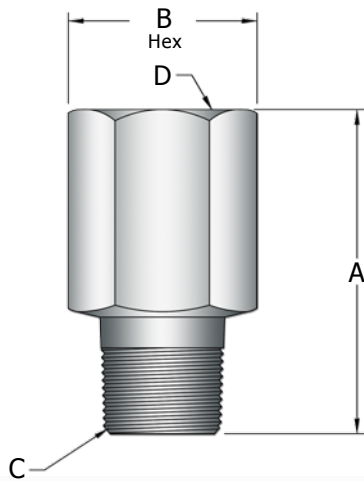

SCMF SERIES CHECK VALVE

Features:

- 316 Stainless Steel Construction
- Precision Custom Cracking Pressure
- Settings (0.5 - 150 psi)
- Viton Seal Standard, Other Elastomers Available, Consult Factory
- 200 psi Max Working Pressure
- Cracks +/- 5% of Set Pressure
- Working Temperature 0°F to 350°F



Dimensions

PART #	A	B	C & D	Cv
SCMF2-*	1.63	0.75	1/4"	0.25
SCMF3-*	2.12	0.87	3/8"	1.09
SCMF4-*	2.38	1.12	1/2"	1.31
SCMF6-*	2.40	1.25	3/4"	1.37
SCMF8-*	3.61	1.50	1"	2.75

* = Set Pressure

(example: for a 15.5 psi cracking pressure, part# SCMF2-15.5)

Bill of Materials

Material	Description
Body	316 Stainless Steel
Spring	302 Stainless (316 Optional)
Stem	316 Stainless Steel
O-Ring	Viton®
Spring Retainer	316 Stainless Steel

Special Options:

SAE
 BSPT
 BSPP
 Oxygen Clean
 Hastelloy
 (consult factory)

