



## FF150DM Series Pneumatic Actuated Valves

### Features:

#### Actuator

- 80 PSI Minimum, 120 PSI Max.
- Aluminum Construction
- Nitril Seals, Polyamide Friction Guides
- -4°F to 185°F

#### Valve

- Full Port ANSI Class 150 Flange Valve
- ISO 5211 Mounting Pad
- Available with V-Ball Option C/F
- Fire Safe Certified to API607, 6TH Edition
- Designed to ANSI B16.5, B16.10, B16.34
- Complies with NACE MR 0175/ISO 15156 and NACE MR 0103

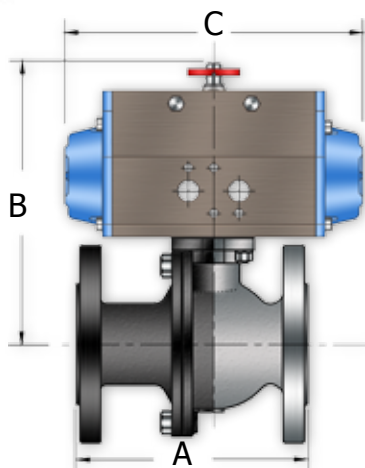

### Double Acting Dimensions:

Part No.	Size	Actuator	A	B	C	D	E	F
PD/*2FF150DM-8	1"	DA52	5.00	5.92	5.88	2.82	0.63x4	0.98
PD/*2FF150DM-12	1-1/2"	DA63	6.50	7.43	6.61	3.29	0.63x4	1.50
PD/*2FF150DM-16	2"	DA75	7.01	8.28	7.32	3.73	0.63x4	1.97
PD/*2FF150DM-24	3"	DA85	7.99	9.64	9.47	4.17	0.75x4	3.00
PD/*2FF150DM-32	4"	DA100	10.05	10.72	10.83	4.84	0.75x8	4.00

\* Option  
**S** = Stainless  
**C** = Carbon

\* Option  
**O** = Fail open  
**C** = Fail Close

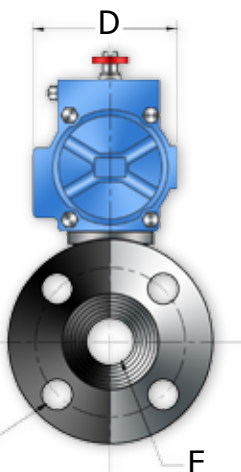

### Spring Return Dimensions:

Part No.	Size	Actuator	A	B	C	D	E	F
P*/*2FF150DM-8	1"	SR63	5.00	6.53	6.61	3.29	0.63x4	0.98
P*/*2FF150DM-12	1-1/2"	SR85	6.50	8.07	9.47	4.17	0.63x4	1.50
P*/*2FF150DM-16	2"	SR100	7.01	8.96	10.83	4.84	0.63x4	1.97
P*/*2FF150DM-24	3"	SR125	7.99	11.59	14.65	5.83	0.75x4	3.00
P*/*2FF150DM-32	4"	SR125	9.02	12.16	14.65	5.83	0.75x8	4.00