



2F3M Series Pneumatic Actuated Valves



Features:

Actuator

- 80 PSI Minimum, 120 PSI Max.
- Aluminum Construction
- Nitril Seals, Polyamide Friction Guides
- -4°F to 185°F

Valve

- Stainless Steel and Carbon Steel
- ISO 5211 Mounting Pad
- 29"Hg-3000PSI (100°F)
- Full Port Ball Valve
- Delrin® Seats with Viton® O-Rings
- NACE MR-0175
- Temperature -20°F to 450°F

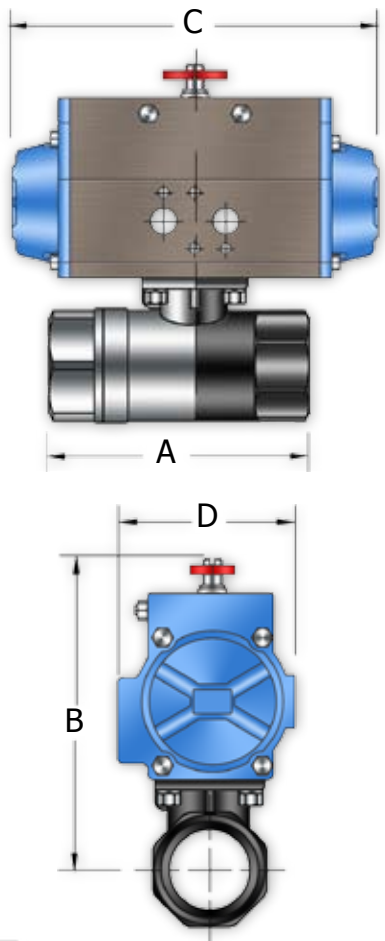

Double Acting Dimensions:

Part No.	Size	Actuator	A	B	C	D
PD/*2F3M-2	1/4"	DA52	2.95	5.23	5.79	2.82
PD/*2F3M-3	3/8"	DA52	2.95	5.23	5.79	2.82
PD/*2F3M-4	1/2"	DA52	2.95	5.23	5.79	2.82
PD/*2F3M-6	3/4"	DA52	3.19	5.35	5.79	2.82
PD/*2F3M-8	1"	DA63	3.58	6.34	6.61	3.29
PD/*2F3M-10	1-1/4"	DA75	4.33	7.06	7.24	3.73
PD/*2F3M-12	1-1/2"	DA75	4.76	7.33	8.27	3.72
PD/*2F3M-16	2"	DA75	5.71	7.33	8.27	3.72

* Option
O = Fail open
C = Fail Close

* Option
S = Stainless
C = Carbon

Spring Return Dimensions:

Part No.	Size	Actuator	A	B	C	D
P*/*2F3M-2	1/4"	SR63	2.95	5.84	6.61	3.29
P*/*2F3M-3	3/8"	SR63	2.95	5.84	6.61	3.29
P*/*2F3M-4	1/2"*	SR75	2.95	7.91	7.24	3.73
P*/*2F3M-6	3/4"*	SR75	3.19	8.02	7.24	3.73
P*/*2F3M-8	1"	SR85	3.58	7.54	10.83	4.84
P*/*2F3M-10	1-1/4"*	SR110	4.33	10.59	13.11	5.39
P*/*2F3M-12	1-1/2"	SR115	4.76	9.35	13.11	5.39
P*/*2F3M-16	2"	SR115	5.71	9.35	13.11	5.39

* Note: These sizes use a bracket in the assembly