



BGF SERIES BALL VALVE



MSS SP-110 Compliant

Features:

- Brass Full Port Ball Valve
- 29" Hg-600psi WOG, Cold Non-Shock
- Blow Out Proof Stem & Adjustable Stem Packing
- Temperature -0°F to 366°F
- NPT Standard Available Solder C/F
- Optional Nickel Plated Available, BGF-NP Series

Dimensions

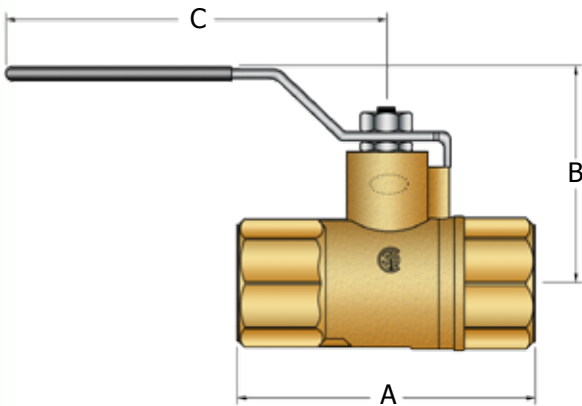

PART #	NPT	A	B	C	ØD*	Cv	Wt. Lbs.
BGF-2	1/4"	1.75	1.84	3.54	0.40	6	0.33
BGF-3	3/8"	1.76	1.84	3.54	0.41	7	0.30
BGF-4	1/2"	2.05	1.92	3.54	0.58	19	0.44
BGF-6	3/4"	2.36	2.09	3.78	0.75	34	0.66
BGF-8	1"	2.76	2.56	4.53	0.95	50	1.10
BGF-10	1-1/4"	3.31	2.95	4.53	1.26	104	1.57
BGF-12	1-1/2"	3.66	3.35	5.51	1.58	268	2.40
BGF-16	2"	4.18	3.68	5.51	1.97	309	3.37
BGF-20	2-1/2"	5.38	4.76	8.66	2.52	629	7.60
BGF-24	3"	6.04	5.08	8.66	2.95	1018	9.36
BGF-32	4"	7.39	5.87	9.61	3.90	1622	16.85

Bill of Materials

PART	Material
Body	Forged Brass
End Connection	Forged Brass
Ball	Brass, Chrome Plated
Stem	Brass, Chrome Plated
Ball Seats	PTFE
Stem Packing	PTFE
Gland Nut	Brass
Thrust Washer	PTFE
Handle	Steel
Handle Cover	PVC
Handle Nut	Steel
O-Ring	NBR (2-1/2" to 4" only)

